

Planungs-Richtlinie und Montageanleitung
Id.-Nr. 894345 beachten

1	Netzanschlussklemme
2	Ablauf nach vorn
3	Bedienblende f. Einbau in CNS t=1
4	Ausbruch f. Bedienblende in CNS t=1

Bearbeitet:	Tag 02.02.26	Name Ott	Massblatt Bratplatte 400 X-Line Drop-In Einbaumodul	Maßstab: 1:5
Gepr.Konstr.:				
Freigabe:				
			XL867896MB	
PALUX Aktiengesellschaft D-97980 Bad Mergentheim				

XL867896	Bratplatte 400	Ablauf n. vorn	4 kW
Id.-Nr.	Benennung	Beschreibung	Leistung

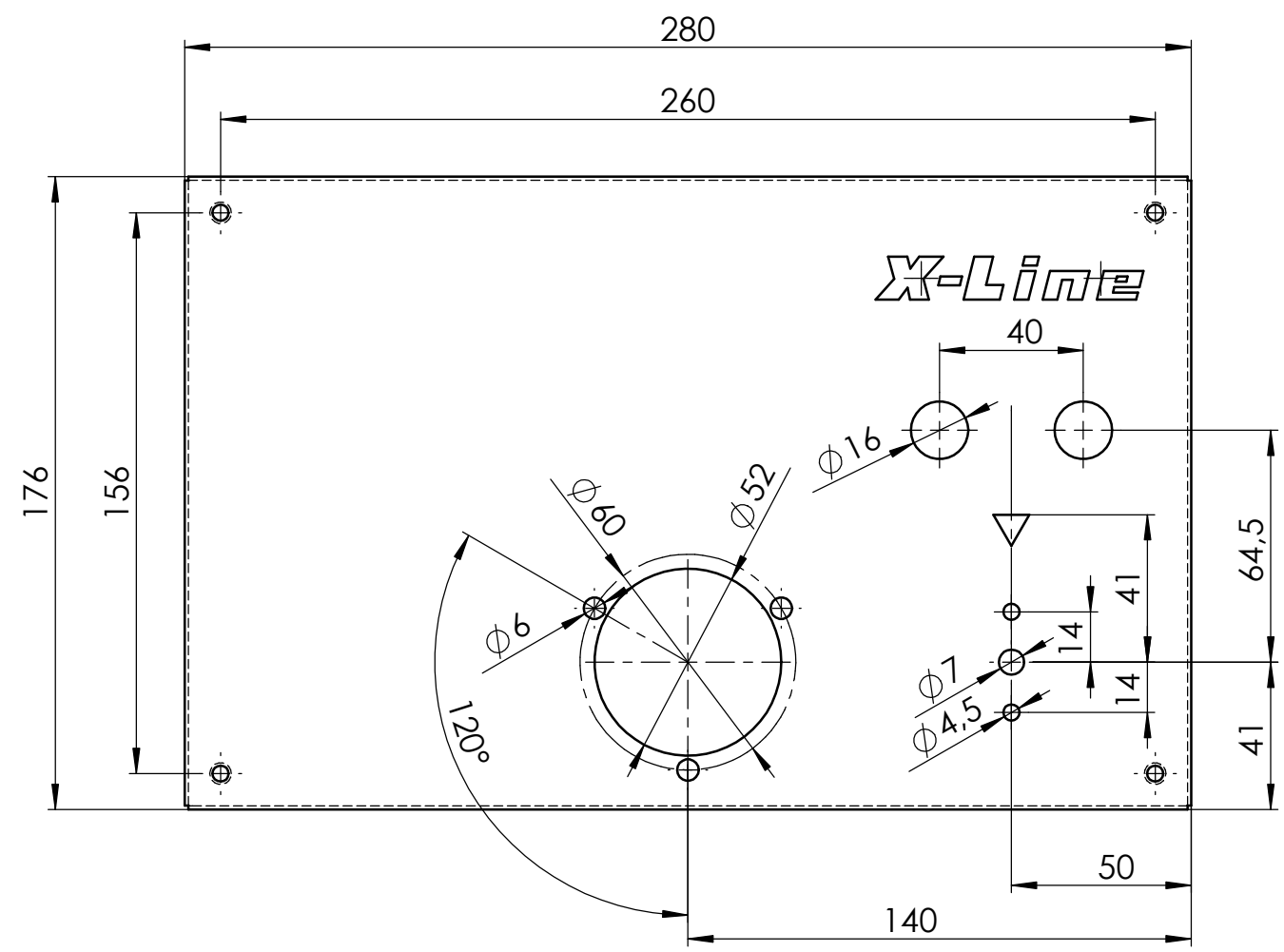

③

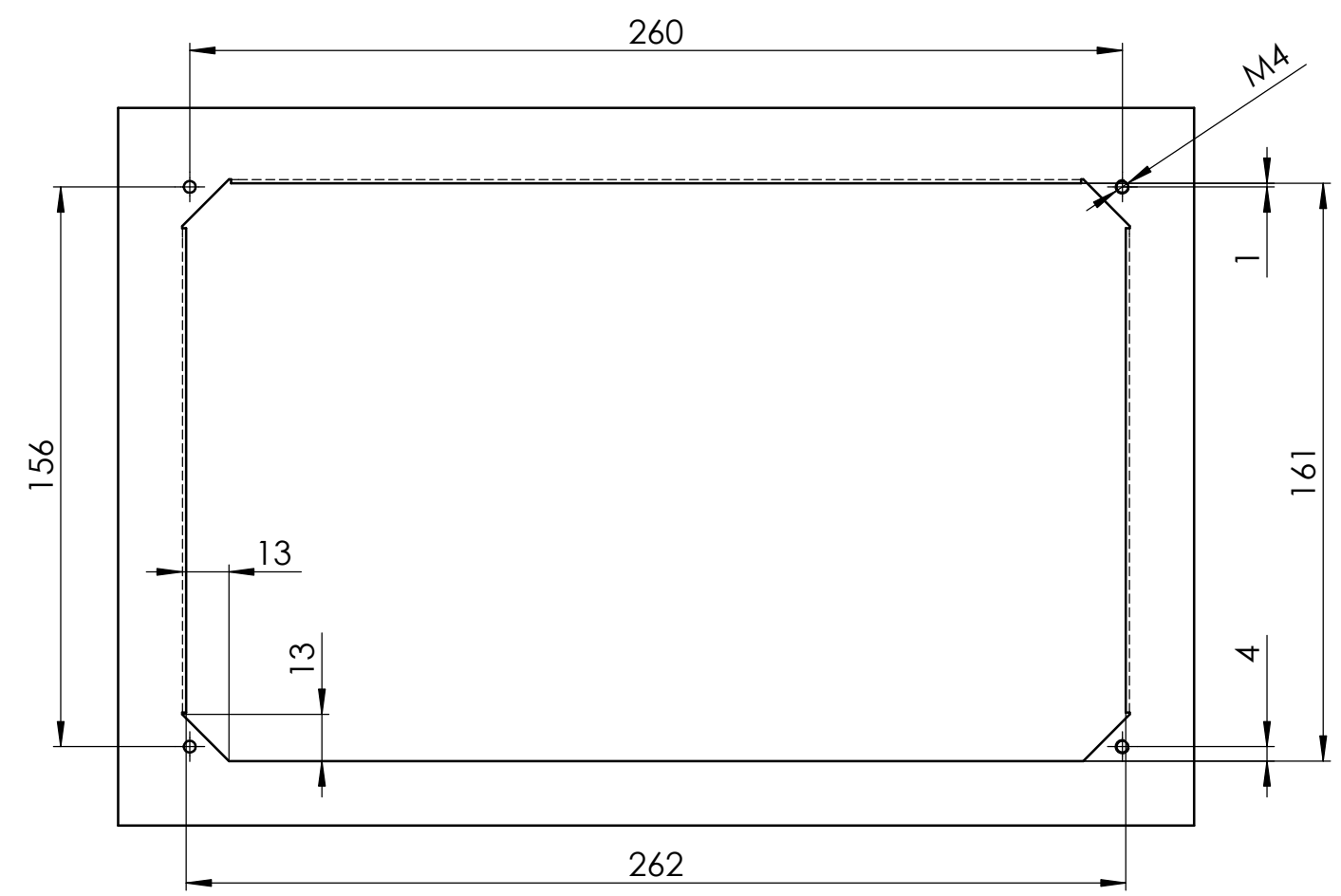
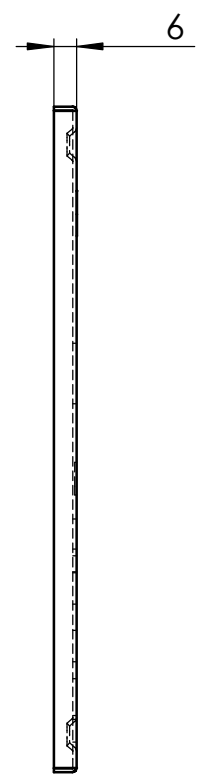

④

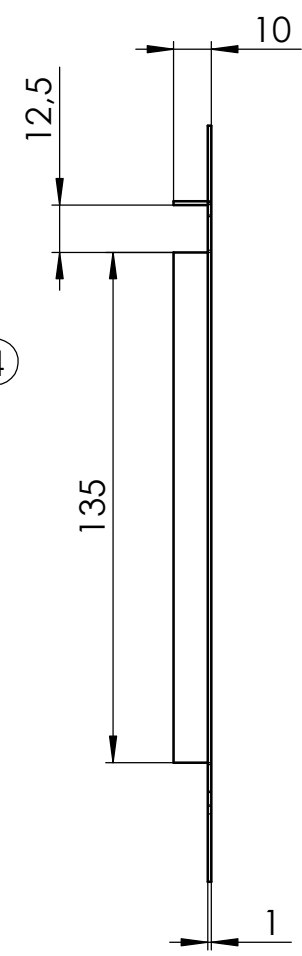

Blatt 2

	Tag	Name		
Bearbeitet:	02.02.26	Ott	Massblatt Bratplatte 400 X-Line Drop-In Einbaumodul	Maßstab: 1:2
Gepr.Konstr.:				
Freigabe:				
			XL867896MB	
PALUX Aktiengesellschaft D-97980 Bad Mergentheim				