

Befestigung Halteblech f. Netzanschlussklemme  
Bohrung STB-Rückstellung

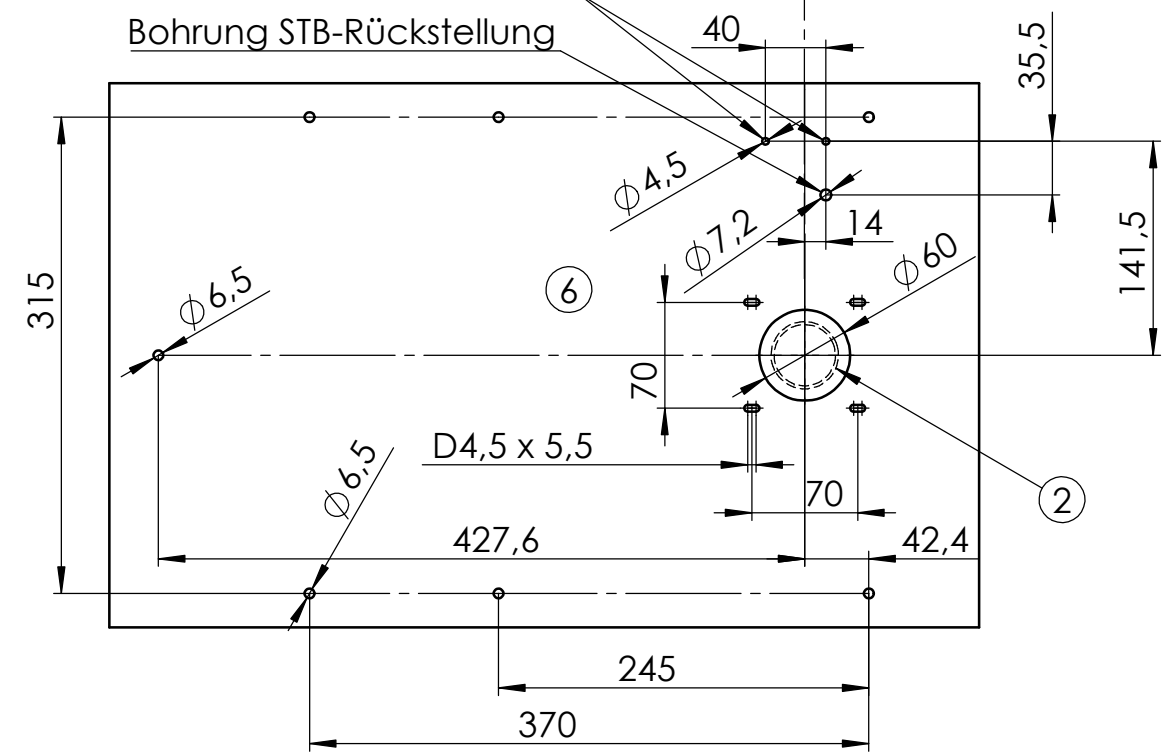

Planungs-Richtlinie und Montageanleitung  
Id.-Nr. 894345

1	Netzanschlussklemme
2	Ablauf nach unten
3	Bedienblende f. Einbau in CNS t=1
4	Abdeckblech Rohrdurchführung
5	Ausbruch f. Bedienblende in CNS t=1
6	Ausbruch f. Ablauf nach unten

Bearbeitet:	Tag 02.02.26	Name Ott	Massbl. Bratplat. 400 Abl.n.u. X-Line Drop-In Einbaumodul	Maßstab: 1:5
Gepr. Konstr.:				
Freigabe:				



**XL877143MB**

PALUX Aktiengesellschaft  
D-97980 Bad Mergentheim

XL877143	Bratplatte 400	Ablauf n. unten	4 kW
Id.-Nr.	Benennung	Beschreibung	Leistung

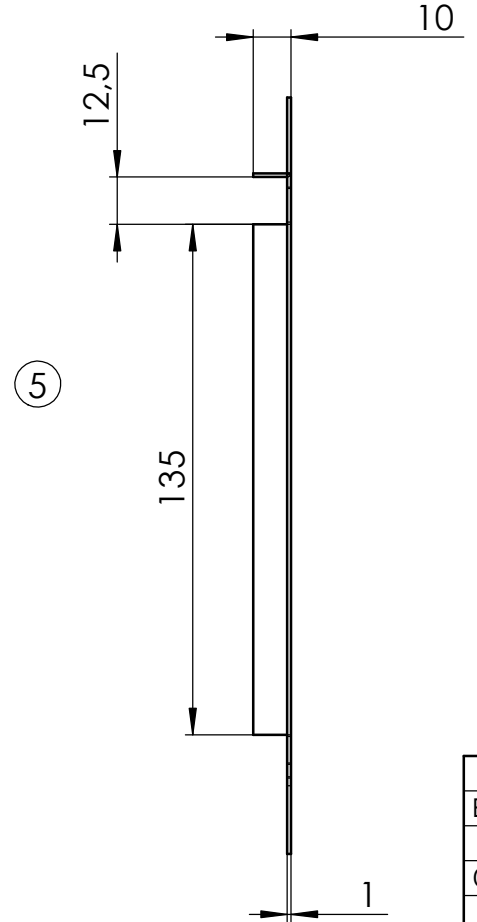
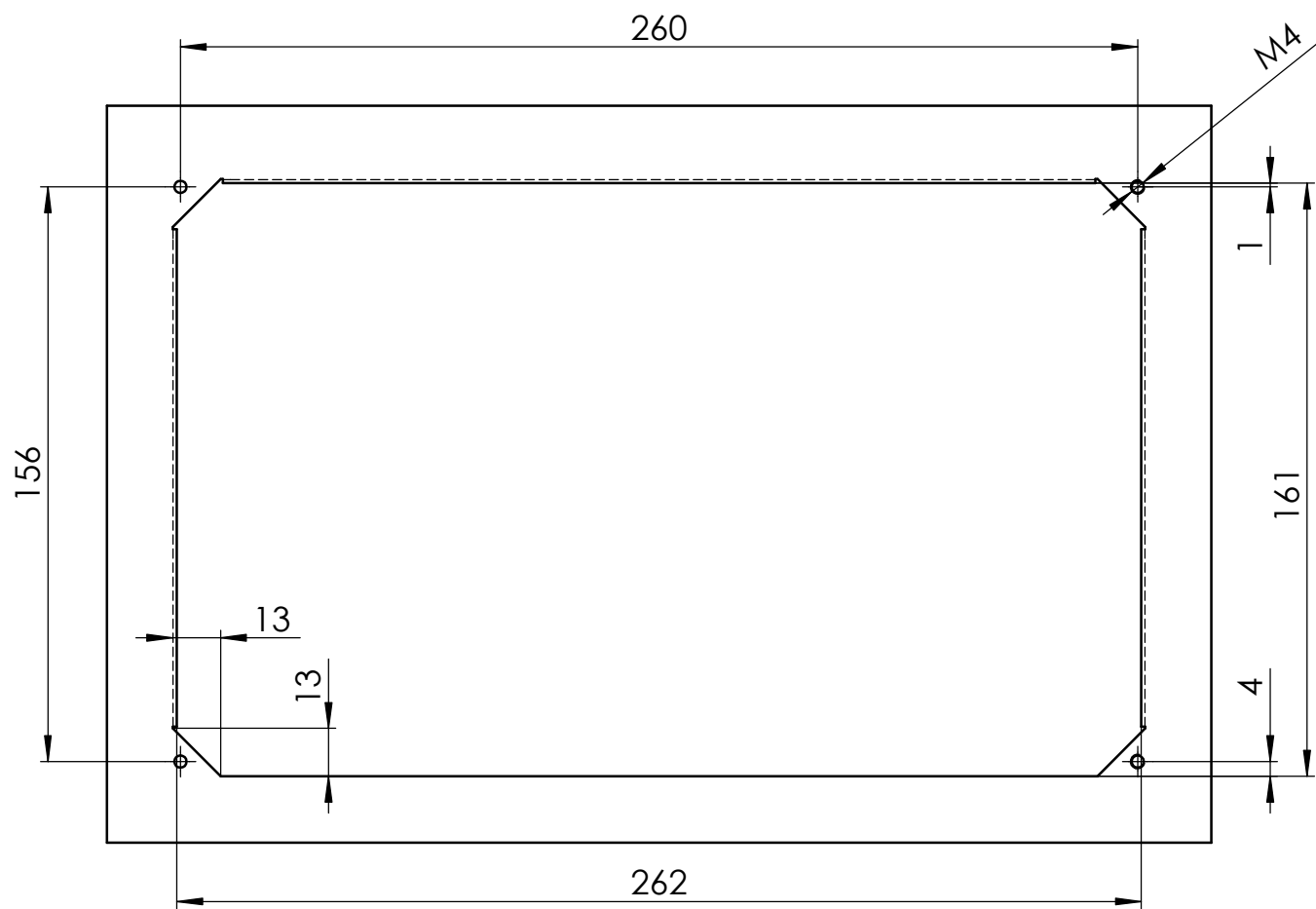
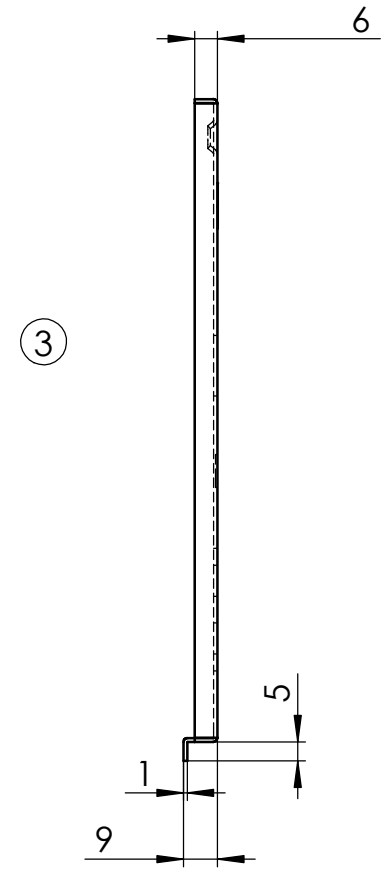
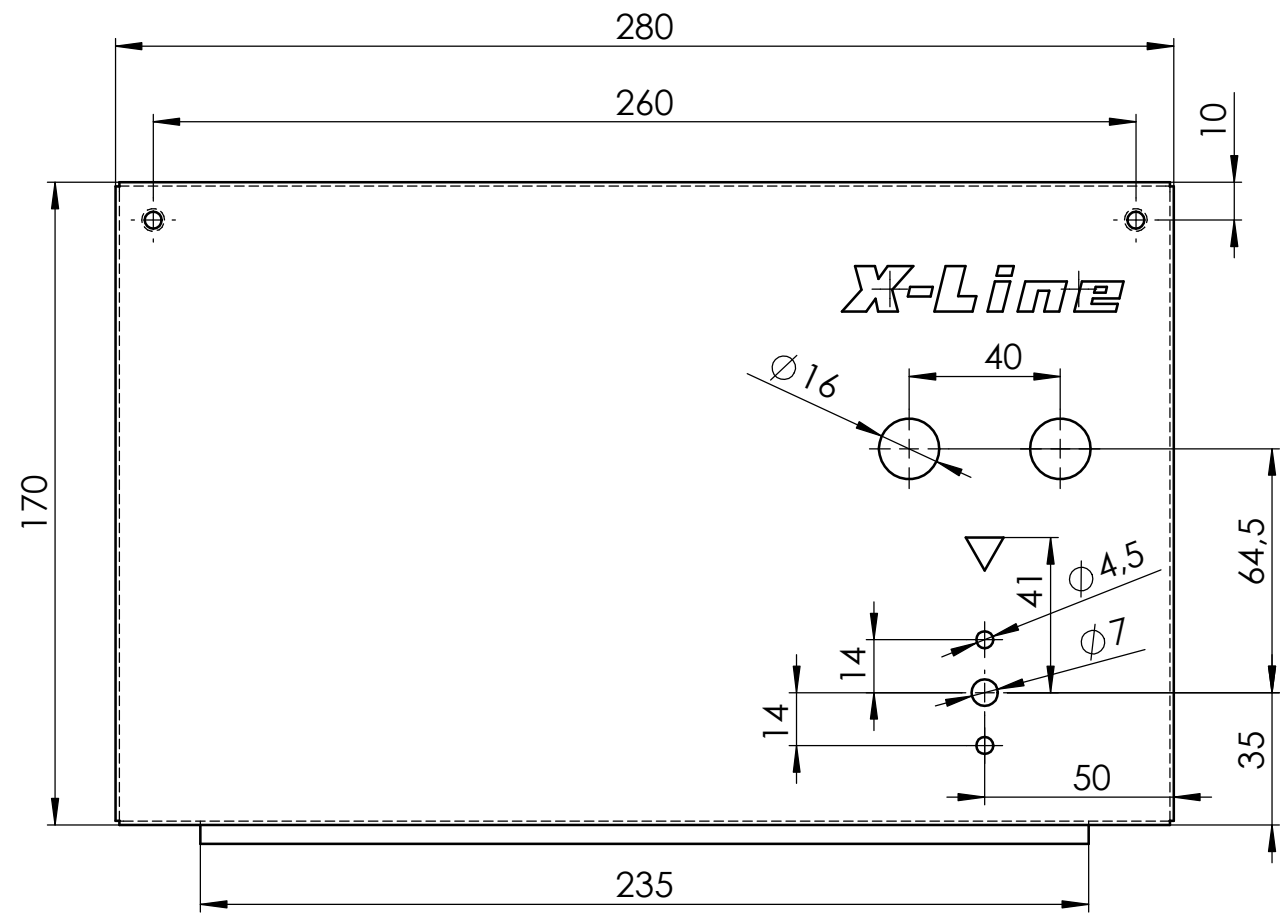

Blatt 2

Bearbeitet:	Tag 02.02.26	Name Ott	Massbl.Bratplat.400 Abl.n.u. X-Line Drop-In Einbaumodul	Maßstab: 1:2
Gepr.Konstr.:				
Freigabe:				
			<b>XL877143MB</b>	
PALUX Aktiengesellschaft D-97980 Bad Mergentheim				