

Befestigung Halblech f. Netzanschlussklemme  
Bohrung STB-Rückstellung

Planungs-Richtlinie und Montageanleitung Id.-Nr. 894345 beachten

- 1 Netzanschlussklemme
- 2 Ablauf nach unten
- 3 Bedienblende f. Einbau in CNS t=1
- 4 Abdeckblech Rohrdurchführung
- 5 Ausbruch f. Bedienblende in CNS t=1
- 6 Ausbruch f. Ablauf nach unten

Bearbeitet:	Tag 06.02.26	Name Ott
Gepr.Konstr.:		
Freigabe:		
<b>PALUX</b>		
PALUX Aktiengesellschaft D-97980 Bad Mergentheim		

<b>MB Grill-/Bratp.600 Abl.n.u.</b>		Maßstab: 1:5
X-Line Drop-In Einbaumodul		
<b>XL882632MB</b>		

XL882632	Grill-/Bratplatte 600	Ablauf n. unten	8 kW
Id.-Nr.	Benennung	Beschreibung	Leistung

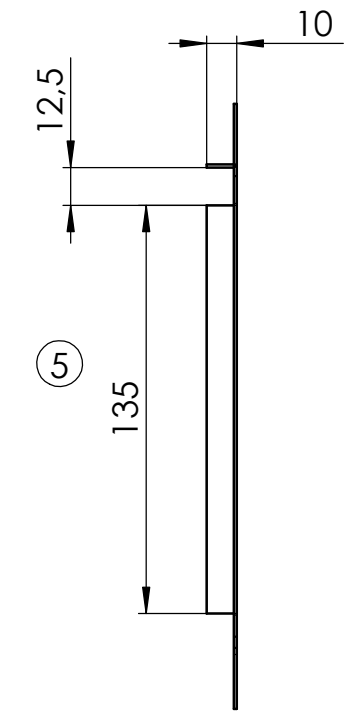
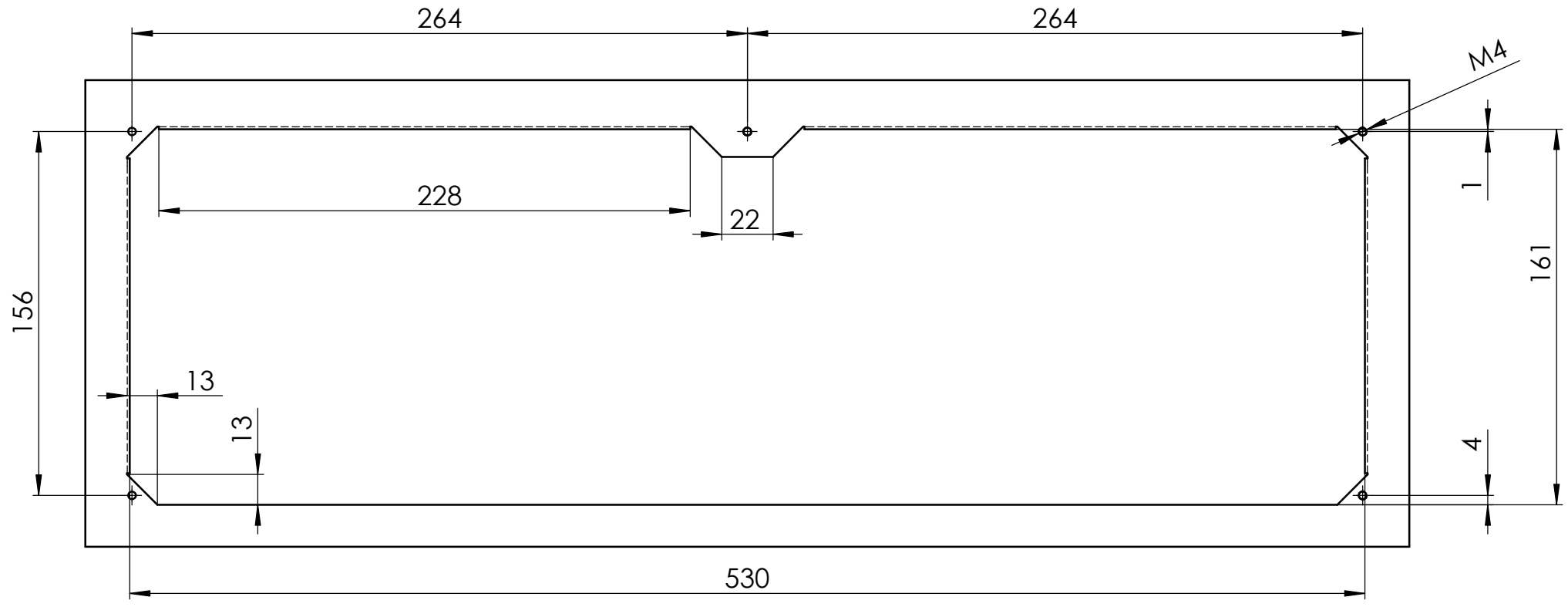
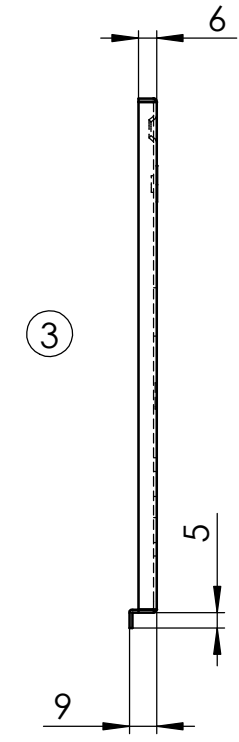
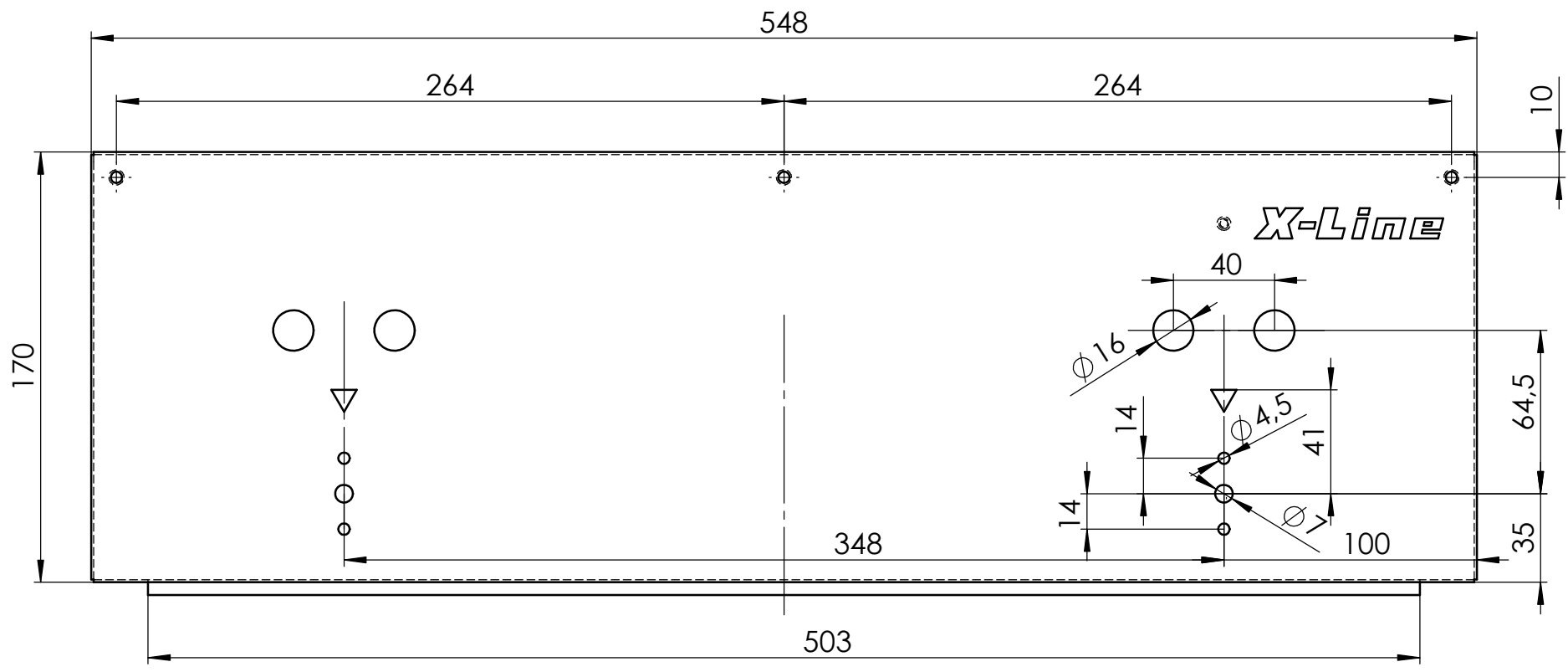

	Tag	Name	
Bearbeitet:	06.02.26	Ott	
Gepr.Konstr.:			MB Grill-/Bratp.600 Abl.n.u. X-Line Drop-In Einbaumodul
Freigabe:			
			Maßstab: 1:2.5
PALUX Aktiengesellschaft D-97980 Bad Mergentheim			
<b>XL882632MB</b>			