

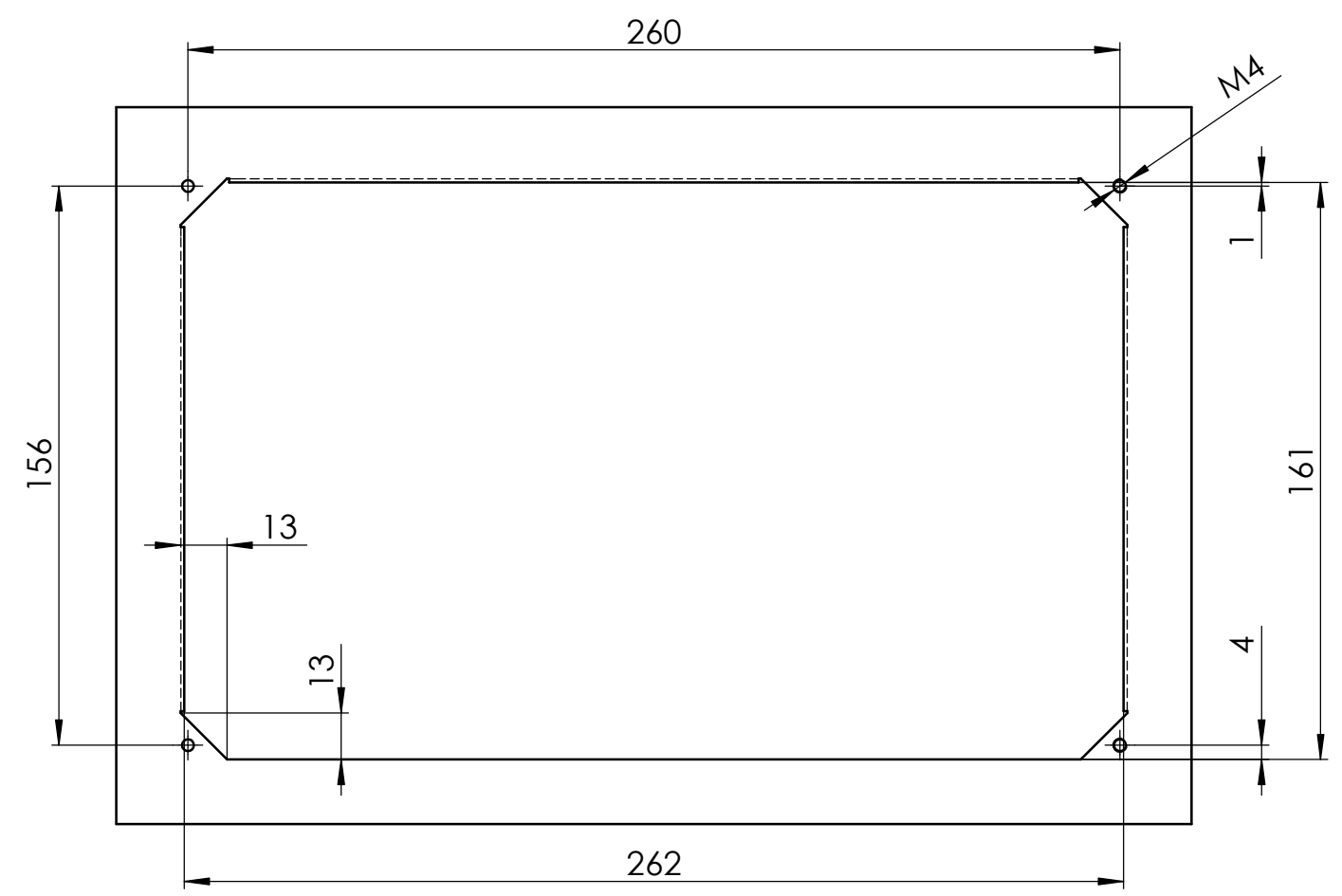

2

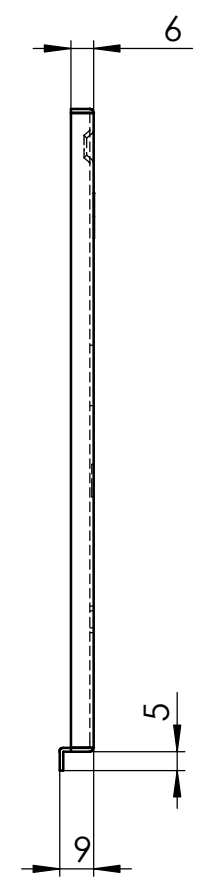

3

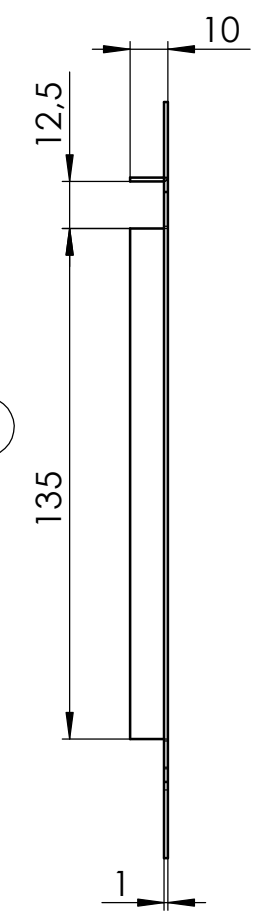

Blatt 2

	Tag	Name		
Bearbeitet:	17.02.26	Ott	Massblatt Ceranherd F3 X-Line Drop-In Einbaumodul	Maßstab: 1:2
Gepr.Konstr.:				
Freigabe:				
			XL922455MB	
PALUX Aktiengesellschaft D-97980 Bad Mergentheim				