

Befestigung Halblech f. Netzanschlussklemme

Bohrung STB-Rückstellung

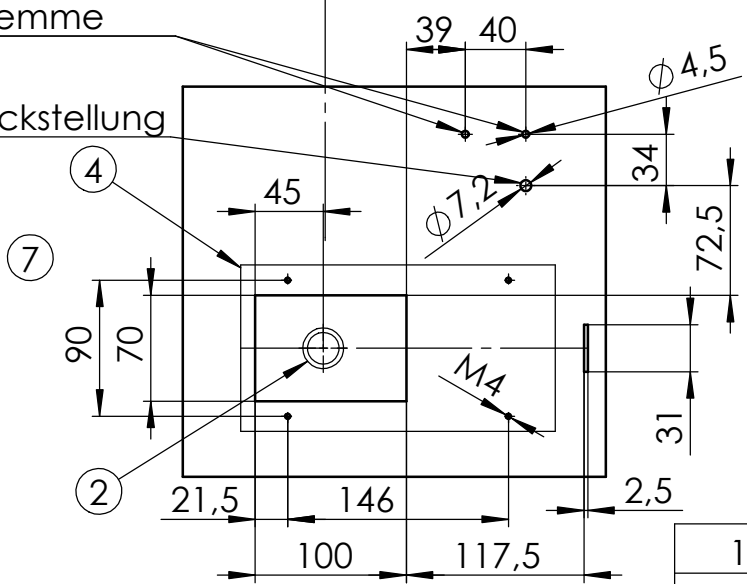

Planungs-Richtlinie und Montageanleitung Id.-Nr. 894345 beachten

1	Netzanschlussklemme
2	Ablauf nach unten
3	Bedienblende f. Einbau in CNS t=1 (M 1:5)
4	Abdeckung Kugelhahnbetätigung
5	Sicherheitsklappe f. Kugelhahnbetätigung
6	Ausbruch f. Bedienblende in CNS t=1 (M 1:5)
7	Ausbruch f. Abdeckung Kugelhahnbet. (M 1:5)

	Tag	Name
Bearbeitet:	22.01.2026	Ott
Gepr.Konstr.:		
Freigabe:		

<p>Massblatt Fritteuse 2B Abl. n. u. X-Line Drop-In Einbau.</p>		<p>Maßstab: 1:5</p>
--	--	-------------------------



XL977233MB

XL977233	Fritteuse 600	Ablauf n. unten	2x8 kW
Id.-Nr.	Benennung	Beschreibung	Leistung

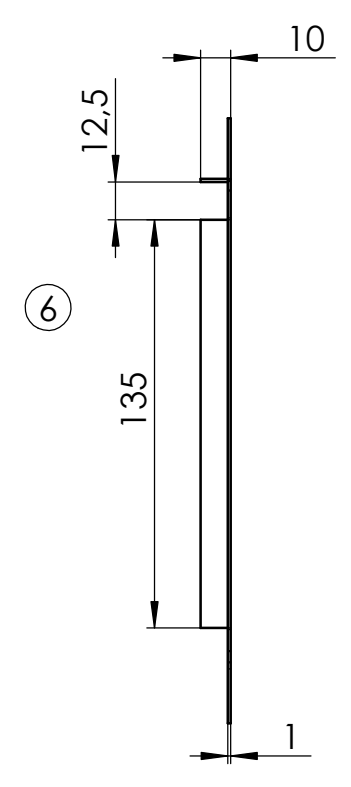
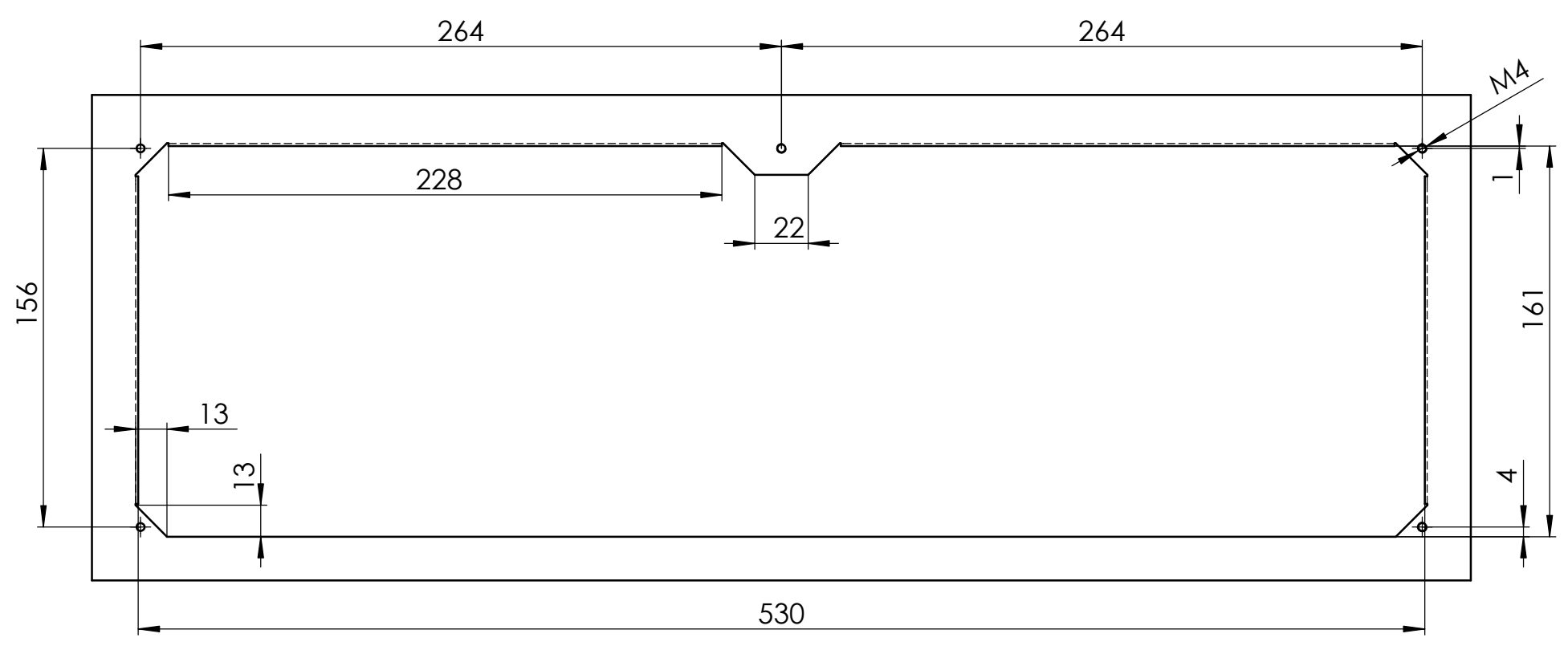
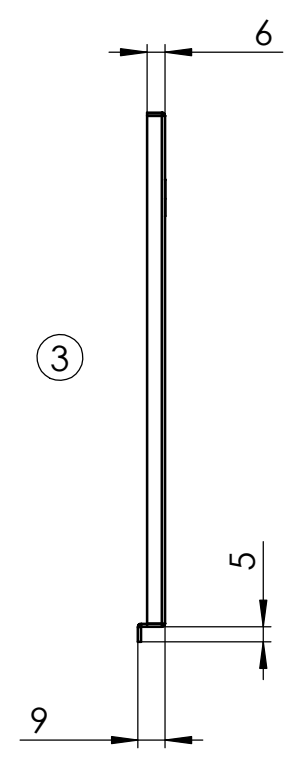
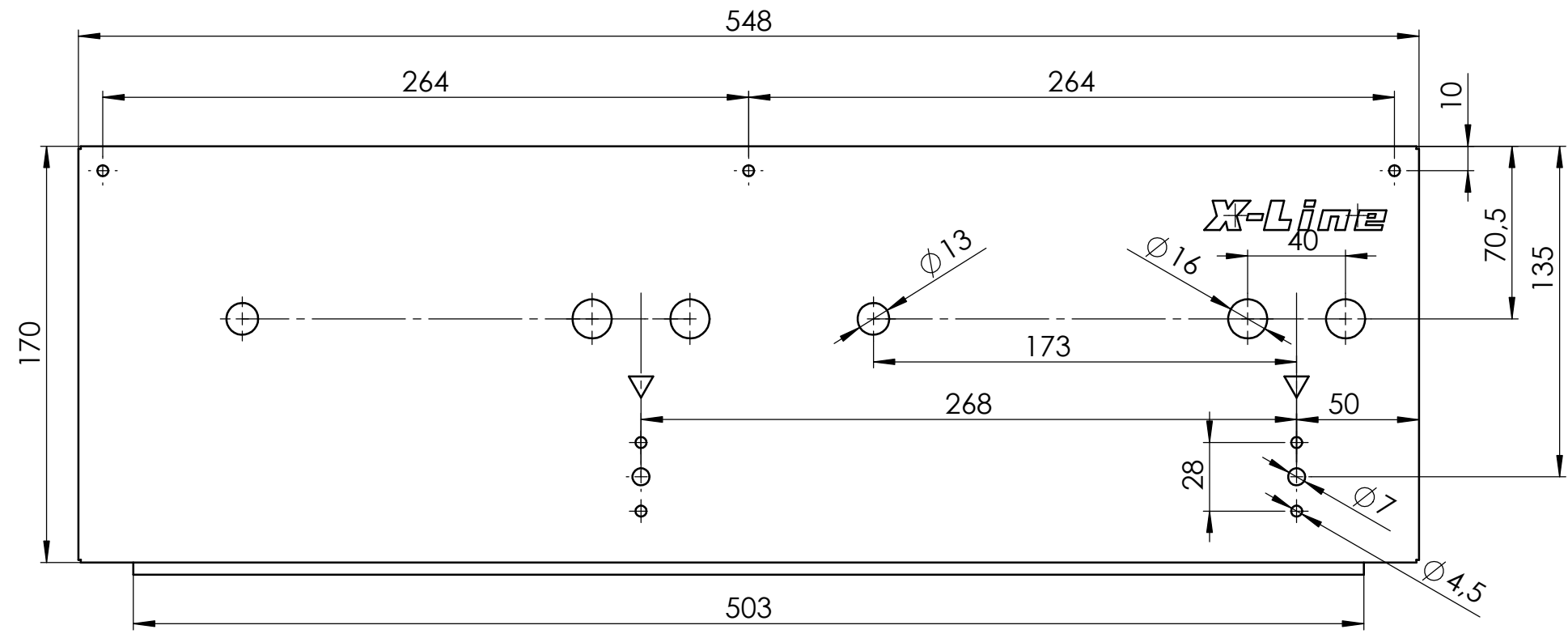

	Tag	Name	
Bearbeitet:	22.01.2026	Ott	
Gepf.Konstr.:			
Freigabe:			
			Massblatt Fritteuse 2B Abl. n. u. X-Line Drop-In Einbau.
			XL977233MB
PALUX Aktiengesellschaft D-97980 Bad Mergentheim			Maßstab: 1:2.5