

- 1 Bedienblende f. Einbau in CNS t=1
- 2 Ausbruch f. Bedienblende in CNS t=1
- 3 Schublade

Planungs-Richtlinie und  
Montageanleitung  
Id.-Nr. 894345 beachten

Bearbeitet:	Tag 20.02.26	Name Ott	<b>Massblatt Gasgrill 600 2 Zo</b> X-Line Drop-In Einbaumodul	Maßstab: 1:5
Gepr.Konstr.:				
Freigabe:				
			<b>XL926124MB</b>	
PALUX Aktiengesellschaft D-97980 Bad Mergentheim				

Blatt 1

XL926124	Gas-Grill	Einbaumodul	10,3 kW
Id.-Nr.	Benennung	Beschreibung	Leistung

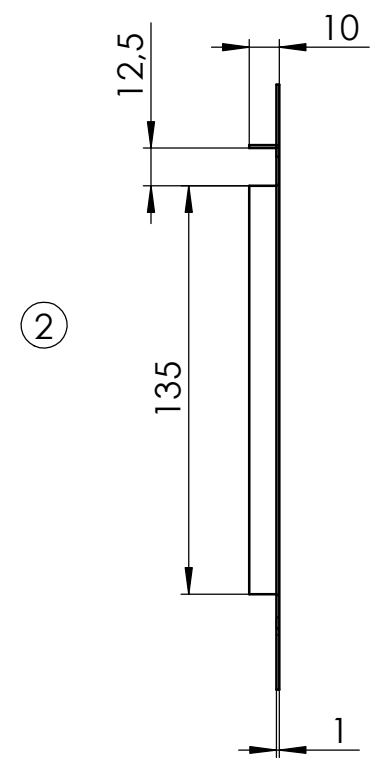
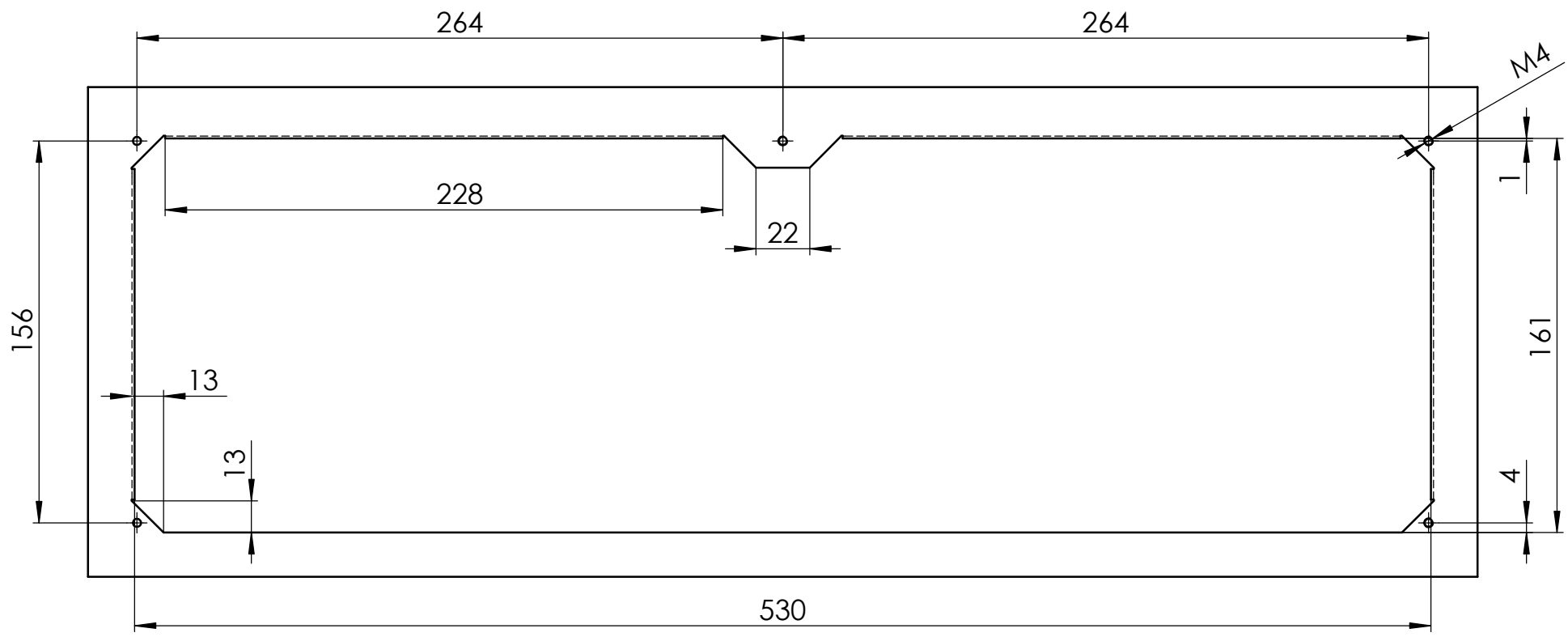
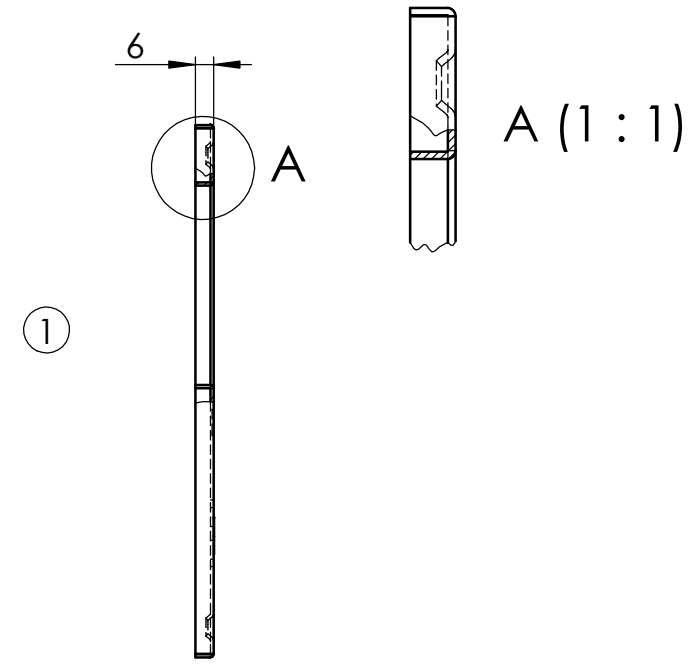
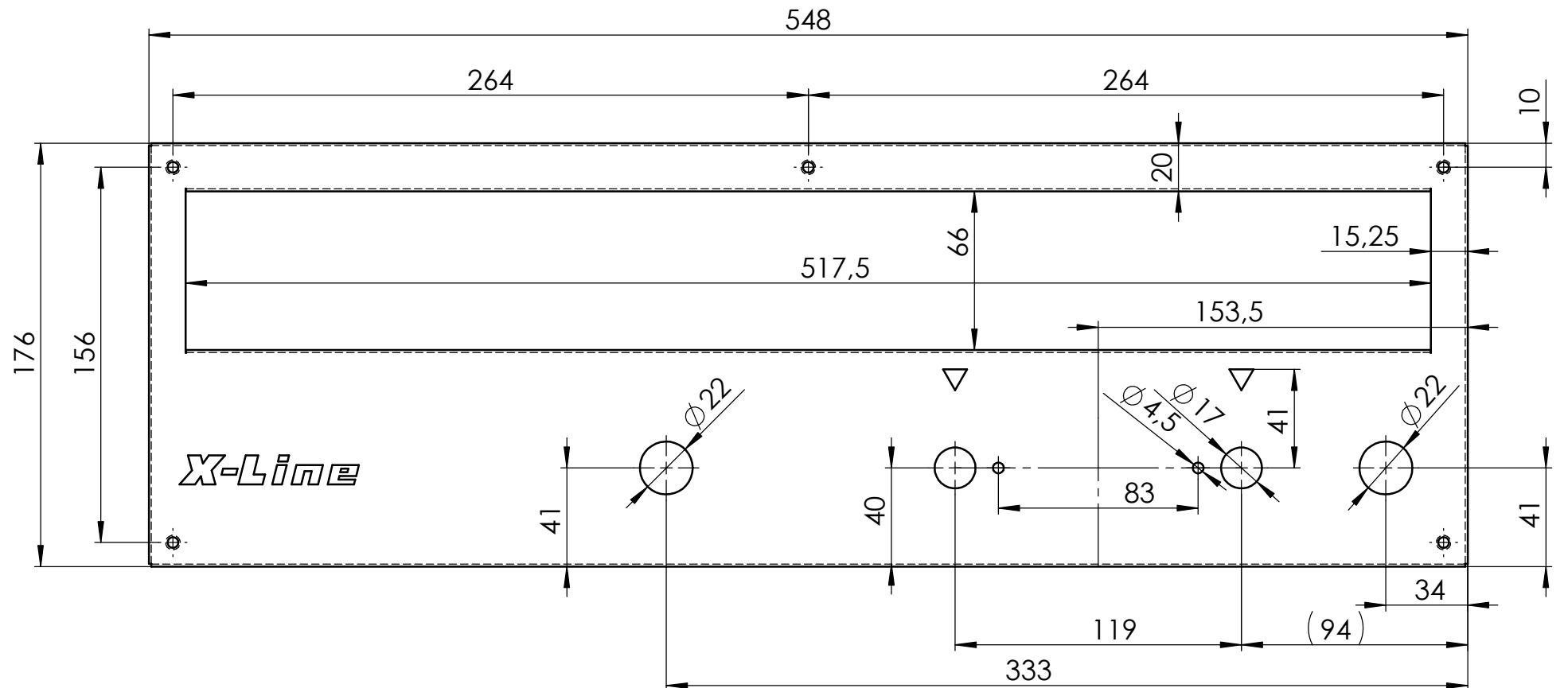

Bearbeitet:	Tag 20.02.26	Name Ott	Massblatt Gasgrill 600 2 Zo X-Line Drop-In Einbaumodul	Maßstab: 1:2.5
Geptr.Konstr.:				
Freigabe:				
			<b>XL926124MB</b>	
PALUX Aktiengesellschaft D-97980 Bad Mergentheim				