

Planungs-Richtlinie und Montageanleitung Id.-Nr. 894345 beachten

1	Netzanschlussklemme
2	Ablauf nach unten
3	Bedienblende f. Einbau in CNS t=1
4	Abdeckblech Rohrdurchführung
5	Ausbruch f. Bedienblende in CNS t=1
6	Ausbruch f. Ablauf nach unten

Bearbeitet:	Tag 10.02.26	Name Ott	Massbl.Steakgr.400 Abl.n.u. X-Line Drop-In Einbaumodul	Maßstab: 1:5
Gepr.Konstr.:				
Freigabe:				

Blatt 1

XL877145	Steakgrill 400	Ablauf n. unten	3,6 kW
Id.-Nr.	Benennung	Beschreibung	Leistung



**XL877145MB**

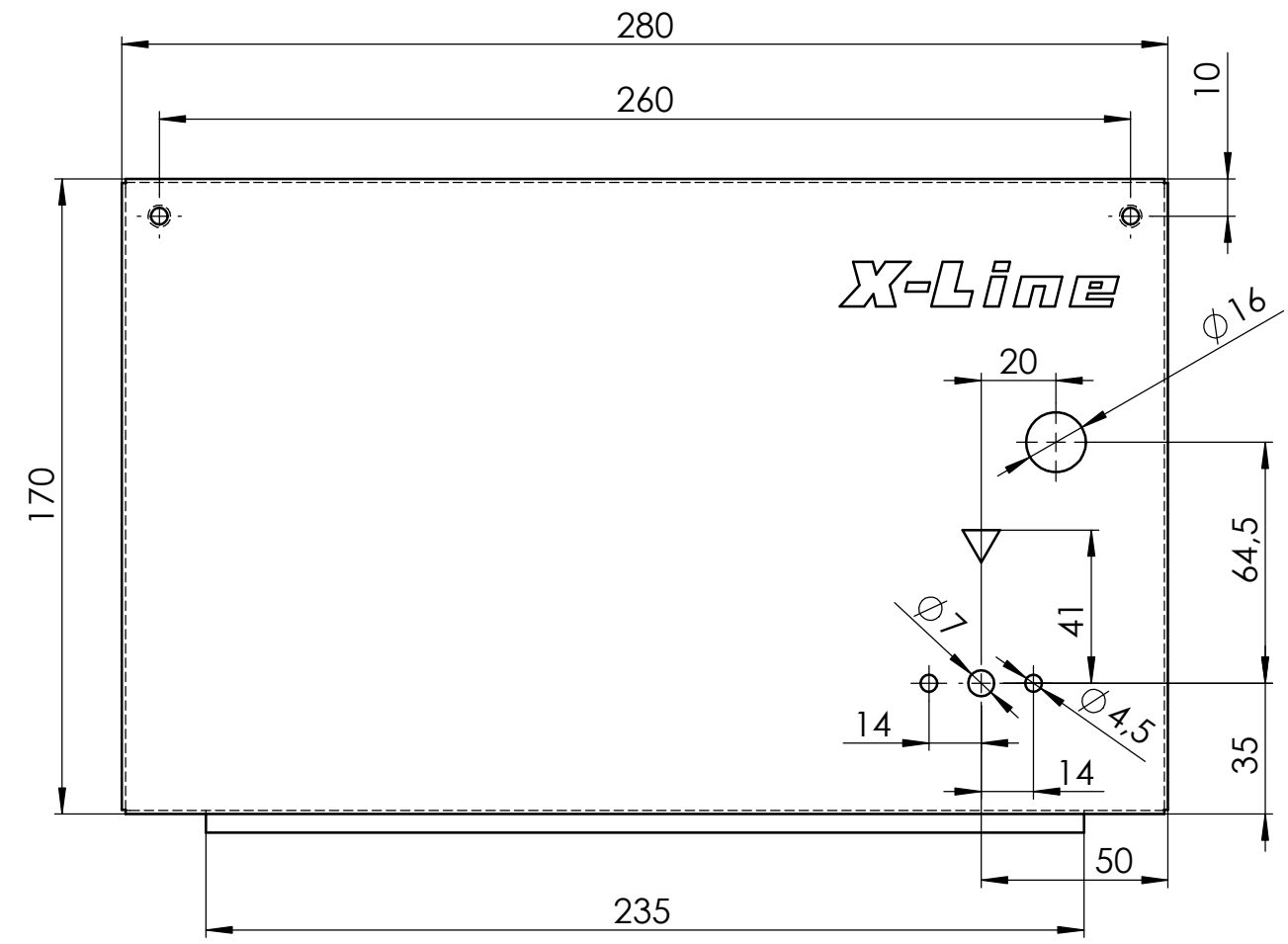

③

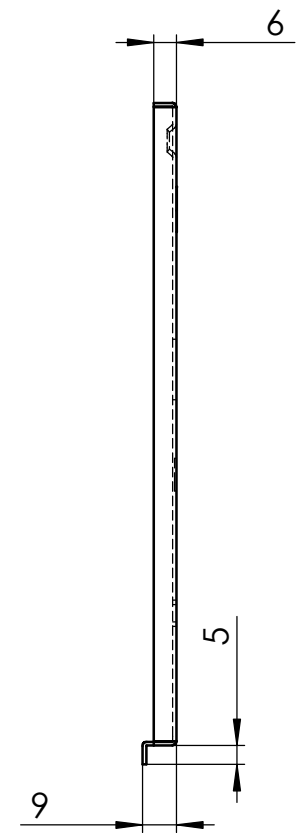

⑤

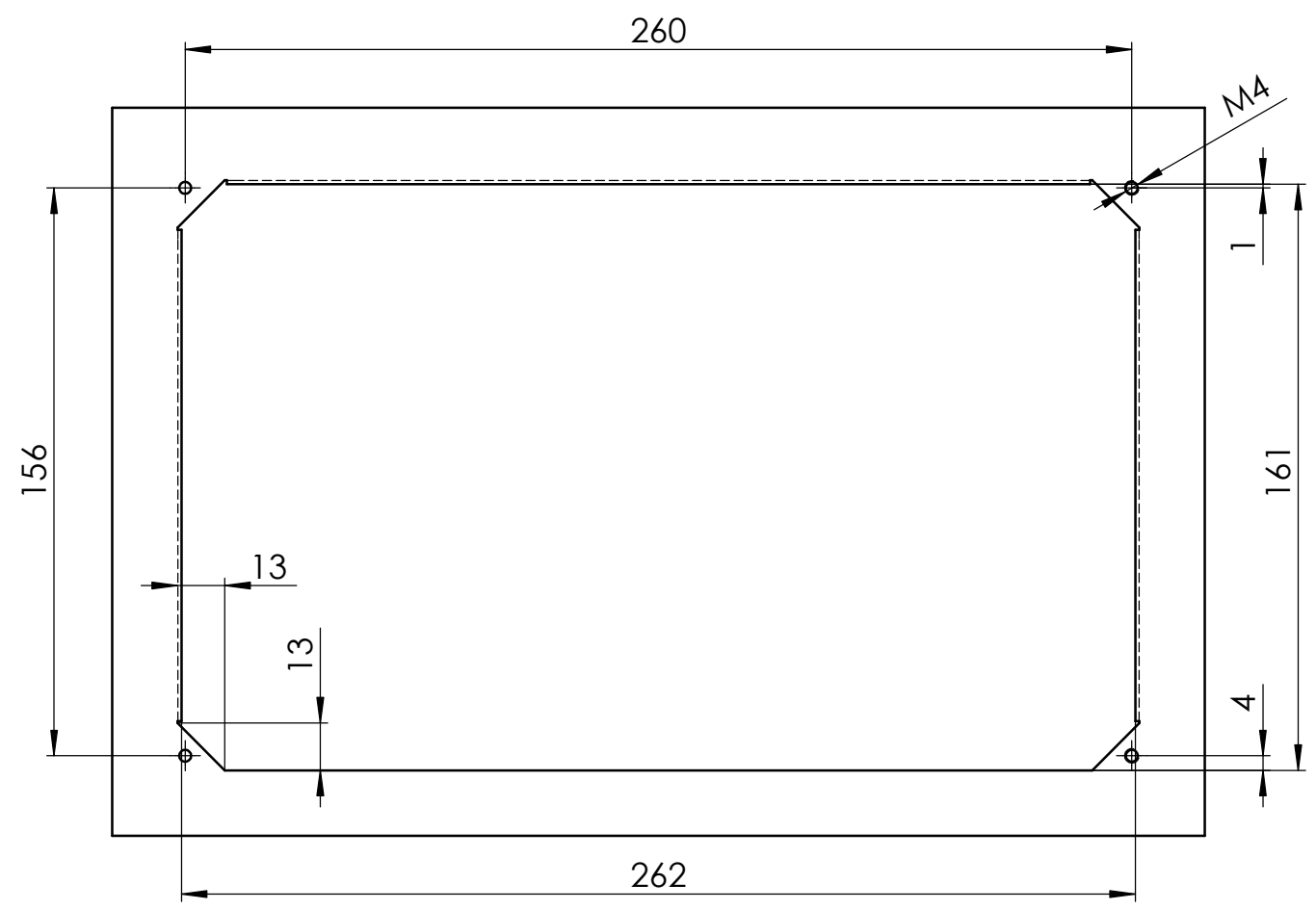
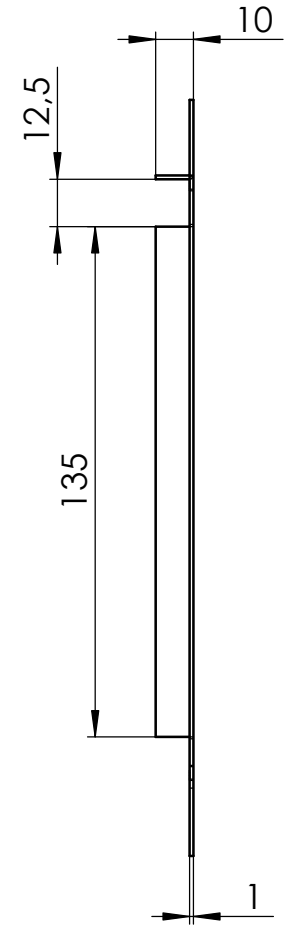

Bearbeitet:	Tag 10.02.26	Name Ott	Massbl.Steakgr.400 Abl.n.u. X-Line Drop-In Einbaumodul	Maßstab: 1:2
Gepr.Konstr.:				
Freigabe:				
			XL877145MB	
PALUX Aktiengesellschaft D-97980 Bad Mergentheim				