



**REFINED.**

Deep fryers

PALUX Fry Star

**PALUX**

## PALUX Fry Star deep fryer series

Easy to operate and handle.

Compact and powerful.

### PALUX Fry Star deep fryers for professionals

Performance and safety are the focus of the new PALUX Fry Star deep fryers. Greater efficiency due to the new high-performance heating system with a 20% larger surface area and electronic temperature sensor.



#### Electronic control

Temperature sensor sensitivity +/- 1 °C; **precise temperature control through electronic temperature sensors**



#### Oil collection tray and basin

Smooth, **deep-drawn, seamlessly welded basin in radial construction** for easy cleaning.



#### Efficient heating system

**Swivel radiators integrated into the pool with 20% more surface area.** For optimal Energy transfer.



#### Safe cleaning

Removable inlet hose with **heat-resistant handle for safe filling of the cleaned deep-fryer basin.** Can be hooked onto the edge of the basin.



#### Complies with the requirements of the EU Acrylamide Regulation

- High-performance heating element, guarantees frying below 170°C
- Electronic timer and audible signal
- Automatic quantity adjustment AQA



#### Safety for quality and application

- Oil-saving heating programme
- Standardised timer functions
- Four fixed temperature and time programmes



#### Versatile and economical

- Optional basket lifting device
- Dual oil filter system
- Optional mobile version:  
Front feet, rear castors (not for type 21).







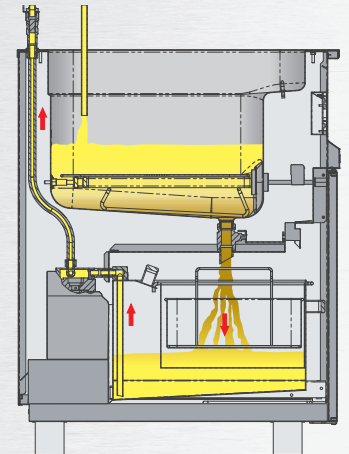

## The PALUX oil filter pump system.

Filter at the touch of a button. Avoid food waste and save operating costs.



## PALUX Fry Star deep fryer

All models are available as freestanding or built-in models with added ease of use. Depending on requirements, optional equipment variants such as the oil/filter pump system or an automatic basket lifting device can be added.

-  **AQA – Automatic Quantity Adjustment.** The cooking time is automatically adjusted by the electronics as per the quantity of food being cooked.
-  **20% larger heating surface. More heat, less energy!** Higher efficiency.
-  **Programmable oil usage time** for less food waste.
-  **Electronic control with hygienic sealed membrane keypad.** Simple and clear user interface..
-  **Energy-saving function** – automatic temperature reduction after 30 minutes of inactivity.
-  **20 preset product buttons.**



**PALUX Fry Star 21**  
Single-basket deep fryer, 200 mm

**PALUX Fry Star 31**  
Single-basket deep fryer 300 mm

**PALUX Fry Star 41**  
Single-basket deep fryer 400 mm

**PALUX Fry Star 42**  
Double-basket deep fryer, 400 mm  
with optional pump and basket lifting  
device



*The new PALUX Fry Star deep fryers stand for maximum performance and reliability in professional kitchens. The innovative high-performance heating system with a 20% larger surface area ensures optimum energy transfer, fast heating times and efficient operation – whilst conserving oil.*

## FACTS AND FIGURES AT A GLANCE

Technical specifications		PALUX Fry Star 21	PALUX Fry Star 31	PALUX Fry Star 41	PALUX Fry Star 42
Dimensions (L × W × H)	mm	200 × 650 × 750/900	300 × 650 × 750/900	400 × 650 × 750/900	400 × 650 × 750/900
Basket size	mm	140 × 320 × 155	220 × 320 × 155	300 × 320 × 155	2 × 140 × 320 × 155
Basket capacity	kg	1.25	1.8	2.5	2 × 1.25
Total oil capacity	litre	7.5–9.0	12.5–14.5	17.0–20.5	2 × 7.5–9.0
Connected load	kW	8.0	11.0	16.0	2 × 8.0
Voltage		400 V 3 50/60 Hz	400 V 3 50/60 Hz	400 V 3 50/60 Hz	400 V 3 50/60 Hz
Fuse protection	A	3 × 16	3 × 16	3 × 25	2 × (3 × 16)
Number of basins		1	1	1	2
Number of baskets		1	1	1	2
Frying capacity, chilled / 170°C	kg/h	25	36	50	50
Frying capacity, frozen / 170°C	kg/h	20	27	38	38
Temperature control range	°C	50–170/180	50–170/180	50–170/180	50–170/180
Basket lifting device		optional	optional	optional	optional
Integrated oil/fat pump		optional	optional	optional	optional
Mobile design		not possible	optional	optional	optional
Door hinge		right & left	right & left	right & left	right & left

Accessories and special voltages available on request. For connection diagrams and technical details, see the operating instructions. We reserve the right to make changes to performance, dimensions and design.

**PALUX Aktiengesellschaft**  
 Wilhelm-Frank-Straße 36  
 DE-97980 Bad Mergentheim

Contact:  
**Telephone** +49 7931 550  
**E-mail** info@palux.de

Technical Support:  
**Telephone** +49 7931 55 500  
**E-mail** tec-support@palux.de  
[www.palux.de](http://www.palux.de)

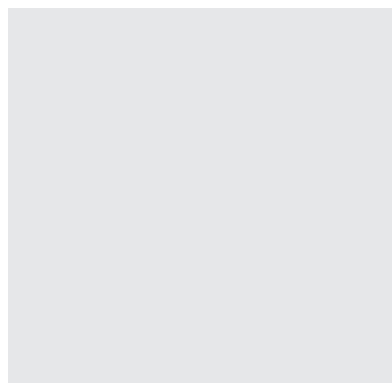

10/2025 - 877165

**PALUX**